



NX Nastran – Dynamic Response

Improving structural dynamic characteristics in your product design results in more innovative, safer and longer lasting products...“right to market”

fact sheet

Siemens PLM Software

www.siemens.com/nx

- ▶ NX™ Nastran® – Dynamic Response software enables you to calculate your product’s forced dynamic response to inputs (loads or motions) that vary with time or frequency. An add-on option to NX Nastran – Basic, it complements the linear static and mode solution capabilities found in the Basic solution. Dynamic response capabilities play a key role in various industries such as assessing passenger comfort in aircraft and automobiles under different operating conditions; determining whether engine frequencies or tire excitations from the road surface will adversely affect responses at other areas of a vehicle, such as at the steering column or in the seats; or evaluating the effect of vibrations on the performance of consumer products and other high-tech electronic devices.

Benefits

Reduce your risk by using simulation to save time and cost compared to physical build-and-break test cycles

Accelerate innovation through rapid iteration and numerous “what-if” studies

Improve confidence in final design by virtually investigating the product’s performance under all possible operating conditions

Designing for maximum performance

The dynamic response of your part or system is governed by its natural frequencies. If your product is excited by inputs having frequencies close to one of its natural frequencies, this will result in a high-amplitude vibratory behavior that could be undesirable, possibly even catastrophic. NX Nastran – Dynamic Response allows you to better understand your product’s dynamic response so that you can design it to avoid exciting those frequencies that could cause it to fail when in operation.

Major capabilities

Comprehensive dynamic response:

- Normal modes and complex eigenanalysis
- Frequency and transient response
- Acoustic response analysis
- Random response analysis
- Response and shock spectrum analysis
- DDAM analysis
- Usable with superelements
- Nonlinear
- Usable with glue connections
- Usable with contact
- Interface to MBD solutions (Adams and Recurdyn)

See Table 1 for a complete list:

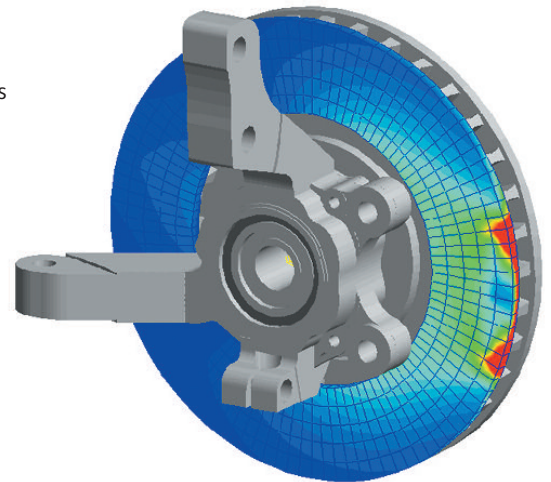

Features

- Comprehensive dynamic response
- Complete library of elements for dynamic analysis
- Many types of damping
- Comprehensive array of eigensolvers
- Dynamic loading with complete generality in the time and frequency domains
- Efficient dynamic analysis methods
- Efficient dynamic data recovery methods
- Efficient solution of large models
- Design sensitivity analysis for assessing changes in dynamic response due to changes in the design
- Ability to interface with numerous programs
- Advanced dynamic analysis capabilities for analyzing complex phenomena
- Batch X-Y plotting for plotting large volumes of data

Table I - Analysis types available with NX Nastran – Dynamic Response

<i>Summary of analysis types</i>	<i>Solution sequence number</i>
Normal modes analysis*	103, 200
Modal frequency response	111, 200
Direct frequency response	108, 200
Modal transient response	112, 200
Direct transient response	109
Acoustic analysis	108, 109, 111, 112, 200
Complex eigenanalysis	107, 110
Random response analysis	108, 111
Nonlinear normal modes	106
Nonlinear complex modes	106
Response spectrum generation	109, 112
Response spectrum application	103
DDAM analysis	187
Design sensitivity-modes*	103, 200
Design sensitivity-frequency response	200
Design sensitivity-transient response	200
Design sensitivity-acoustics	200
Transient response-auto time-stepping**	129

* Also available in the Basic analysis segment

** Nonlinear SOLs that can be run as long as the material properties are linear

Complete library of elements for dynamic analysis, which includes the elements in NX Nastran Basic plus the following:

- Acoustic absorber and barrier
- Damping elements
- Nonlinear-elastic elements for transient response

Many types of damping:

- Structural damping
- Material damping
- Variable modal damping
 - Equivalent viscous
 - Fraction of critical
 - Quality factor
- Discrete viscous dampers
- Acoustic barriers and absorbers
- Direct matrix input

- Nonlinear dampers
- Dynamic transfer functions
- Frequency dependent damping

Comprehensive array of eigensolvers

- Lanczos
- Householder, modified Householder
- Complex Lanczos
- Complex Hessenberg
- Complex inverse power

Dynamic loading with complete generality in the time and frequency domains:

- All static loads can be applied dynamically
- Enforced displacement velocity and acceleration
- Initial displacement and velocity
- Initial displacement from static solution
- Time delays, time windows and analytic and explicit time functions
- Phase angles (real and complex)
- Nonlinear transient loading based on displacement and velocity
- Each load or enforced motion can have a different time history

Efficient dynamic analysis methods:

- Modal and direct solution methods
- Automatic time stepping
- Restarts from previously computed solutions
 - From normal modes to frequency and transient response
 - From frequency response to random response
- Restarts to change loads and analysis parameters
- Capture maximum transient response
- Modal reduction methods
 - Guyan reduction
 - Component modal synthesis
 - Residual vectors for accuracy

Methods to mitigate mode truncation effects

- Residual vectors
- Mode acceleration
- Direct solutions

Efficient solution of large models:

- Sparse matrix solvers for faster speed and minimal disk space available for all analysis types
- Sparse data recovery gives fast solution for limited output
- Automatic internal resequencing for bandwidth reduction
- Parallel and vector processing for faster response calculations
- Superelements

Design sensitivity analysis for assessing changes in dynamic response due to changes in the design:

- Shape and sizing design variables
- Present objective and constraints
 - Weight, volume, eigenvalue
 - Element stress and force
 - Displacement, velocity, acceleration, reaction force
- User-defined objective and constraints
- Sensitivity and optimization for modes, transient response, frequency response, acoustics, statics and buckling all in one run

Ability to interface with numerous programs:

- Geometry can come from CAD and solid modeling programs
- Supported by all popular FE modelers
- Dynamic output can be read by kinematics programs and programs for test-analysis correlation

Advanced dynamic analysis capabilities for analyzing complex phenomena:

- Control systems
- Coupled fluid-structure analysis
- Transfer functions
- Fourier transforms for input loads
- Gyroscopic and Coriolis effects (requires the NX Nastran DMAP option)
- Component mode synthesis (requires the NX Nastran Superelements option)
- Residual vectors for accuracy

Batch X-Y plotting for plotting large volumes of data:

- Plot any response versus time and frequency
- Cartesian, log-log and semi-log plots
- Real/imaginary and magnitude/phase plots
- Single or multiple curves per plot
- Single or multiple plots per page
- Multiple curve and frame line styles
- Save plots in postscript format



Contact

Siemens PLM Software – www.siemens.com/nx

Americas 800 498 5351
Europe 44 (0) 1276 702000
Asia-Pacific 852 2230 3333